

PRODUCT IMAGE



NUTRITION PANEL

Nutrition Facts		
Serving Per Crust		8
Serving Size		1/8 Crust (48g)
Amount per serving		
Calories		85
	% Daily Value*	
Total Fat	0g	0%
Saturated Fat	0g	0%
Trans Fat	0g	
Cholesterol	0mg	0%
Sodium	144mg	6%
Total Carbohydrate	20g	8%
Dietary Fiber	0g	0%
Total Sugars	1g	
Includes 1g Added Sugars		2%
Protein	2g	
Vitamin D	0 mcg	0%
Calcium	20mg	0%
Iron	0.2mg	0%
Potassium	30mg	0%

* The % Daily Value (DV) tells you how much a nutrient in a serving of food contributes to a daily diet. 2,000 calories a day is used for general nutrition advice.

PRODUCT SPECIFICATIONS

ORDER CODE	12CRE12GF
UPC CODE	8-50017-87501-2
DESCRIPTION	3/4CT/12" CAULIFLOWER RAISED-EDGE CRUST
PACKAGE TYPE	SHRINK WRAPPED
INDIVIDUAL CRUST WEIGHT	13 OZ
NET CASE WEIGHT	9.75 LBS
GROSS CASE WEIGHT	11.25 LBS
CASE PACK	3/4CT (12 CRUSTS)
OUTER CASE DIMENSIONS (IN)	12.5 X 12.5 X 8.75
CASE CUBE (FEET)	.79
TI & TIER	9 X 9 (81 Cases)
CODE DATING	PRODUCTION DATE/JULIAN DATE
NET PALLET WEIGHT	790 LBS
GROSS PALLET WEIGHT	945 LBS
SHELF LIFE	9 MONTHS FROZEN
GUARANTEED SHELF LIFE	6 MONTHS FROZEN
SHIPPING TEMPERATURE	SHIP FROZEN AT ZERO F OR BELOW
STORAGE TEMPERATURE	KEEP FROZEN STORE AT ZERO F OR BELOW
DOUBLE STACK	NO

PRODUCT CHARACTERISTICS

PRODUCT THICKNESS	5/16" + OR - 1/8"
PRODUCT DIAMETER	12" + OR - 1/4"
COLOR DESCRIPTION	LIGHT TAN

INGREDIENT STATEMENT

INGREDIENT STATEMENT: FLOUR BLEND (RICE FLOUR, RICE STARCH, POTATO STARCH, XANTHAN GUM, LOCUST BEAN GUM), WATER, CAULIFLOWER, SUGAR, OLIVE OIL, YEAST, SALT, LEAVENING (SODIUM ACID PYROPHOSPHATE, BAKING SODA, MONOCALCIUM PHOSPHATE).



3/4CT/12" CAULIFLOWER RAISED-EDGE PAR-BAKED PIZZA CRUST

EXAMPLE CASE LABEL

bakehousefoods.com

CAULIFLOWER 3/4ct/12" RAISED-EDGE PAR-BAKED PIZZA CRUST

GLUTEN FREE **VEGAN** **100% VEGAN**

INGREDIENT STATEMENT: FLOUR BLEND (RICE FLOUR, RICE STARCH, POTATO STARCH, XANTHAN GUM, LOCUST BEAN GUM), WATER, CAULIFLOWER, SUGAR, OLIVE OIL, SALT, LEAVENING (SODIUM ACID PYROPHOSPHATE, BAKING SODA, MONOCALCIUM PHOSPHATE), YEAST.

NET WT. 11.25 LBS (5.11 KG)

PRODUCT CODE: **12CRE12GF**

PRODUCTION DATE: **06/30/20**

LOT # **20182A**

KEEP FROZEN
STORE AT ZERO DEGREES OR BELOW

FRAGILE
HANDLE LIKE GLASS

(00)850017875012

Nutrition Facts

Serving Per Crust 8
Serving Size 1/8 Crust (83g)

Amount per serving

Calories 90

	% Daily Value*
Total Fat 2g	2%
Saturated Fat 0g	0%
Trans Fat 0g	0%
Cholesterol 0mg	0%
Sodium 228mg	10%
Total Carbohydrate 18g	7%
Dietary Fiber less than 1g	2%
Total Sugars 2g	3%
Includes 2g Added Sugars	3%
Protein 1g	0%
Vitamin D 0 mcg	0%
Calcium 10mg	0%
Iron 0.2mg	0%
Potassium 40mg	0%

*The % Daily Value (DV) tells you how much a nutrient in a serving of food contributes to a daily diet. 2,000 calories a day is used for general nutrition advice.

Manufactured By | Bakehouse Foods, LLC | 24436 Van Born Rd | Dearborn Heights, MI 48125 | Telephone (313) 270-9900

BOX DIMENSIONS

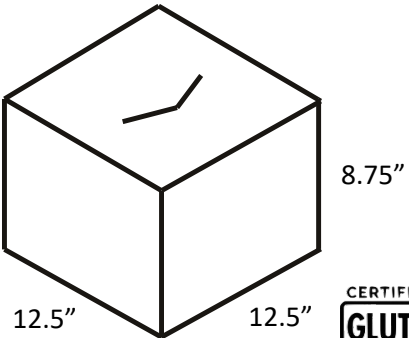

TOPPED BAKING INSTRUCTIONS

OVEN TYPE	TEMPERATURE	BAKE TIME
IMPINGEMENT/CONVEYOR OVEN	500 F	6 – 9 MINUTES
DECK OVEN	520 F	10 – 13 MINUTES
CONVECTION OVEN	400 F	15 – 18 MINUTES
CONVENTIONAL OVEN	400 F	15 – 18 MINUTES
WOOD BURNING OVEN	500 F	6 – 9 MINUTES

TOPPED PIZZA MUST BE COOKED THOROUGHLY TO 160° F FOR FOOD SAFETY AND QUALITY. OVENS MAY VARY SO ADJUST TEMPERATURE AND COOKING TIME AS NEEDED.

- PREHEAT OVEN TO DESIRED COOKING TEMPERATURE AS OUTLINED ABOVE.
- FOR BEST RESULTS, TOP CRUST WHILE STILL FROZEN OR PARTIALLY FROZEN. THAWED CRUST WILL REQUIRE A SHORTER BAKE TIME.
- PLACE CRUST ON TABLETOP OR PREP TABLE. TOP BY APPLYING SAUCE, CHEESE AND CONDIMENTS TO PAR-BAKED CRUST AS DESIRED.
- PLACE TOPPED CRUST DIRECTLY ON OVEN RACK, PIZZA SCREEN OR STEEL BAKING PAN (RECOMMENDED METHOD) AND PLACE IN OVEN FOR THE RECOMMENDED TIME OR UNTIL DESIRED CRISPNESS IS REACHED.
- ALLOW PIZZA TO STAND FOR ONE (1) MINUTE THEN SLICE PIZZA INTO DESIRED NUMBER OF PIECES, SERVE OR PLACE IN BOX FOR TAKE-OUT LOCATIONS.

PALLET PATTERN

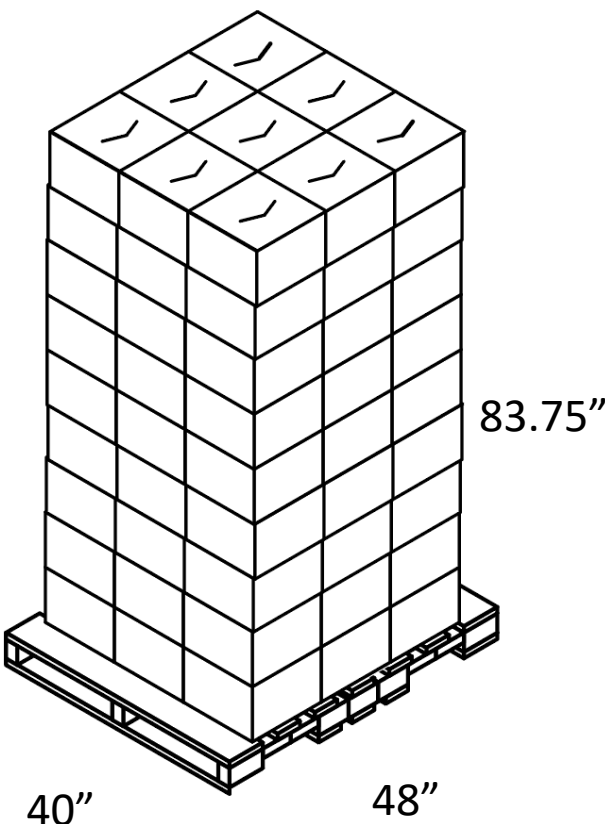

GLUTEN-FREE | ALLERGEN-FREE | PRESERVATIVE-FREE | VEGAN